

With flange connections suitable for EN 1092-1

## USAGE

For observing filling and flow in pipelines. The sight glass enables reliable monitoring of the function and performance of individual devices as well as entire systems. Type 550V flow sight glasses are suitable for installation on flanges according to DIN EN 1092-1. The sight glasses are delivered pre-assembled and ready for installation.

### Operating conditions:

Temperature:	150 °C Soda-lime glass DIN 8902
(depends on glass and gasket)	200 °C <sup>1</sup> Borosilicate glass DIN 7080
Pressure:	-0.998 to 40 barg

1) Limited by the sealing system (novaflon® 500)

## INSTALLATION NOTE

Gaskets should be used that fit exactly to the sealing surfaces. The screw material should correspond to or be of higher quality than that of the sight glass body. Screws must match the drilling pattern of the flanges. Threads and screw heads should be treated with lubricants as much as possible. Flow sight glasses must be installed free of stress – pipe forces, vibrations, and pressure shocks must not affect the fitting.

## DRAWING

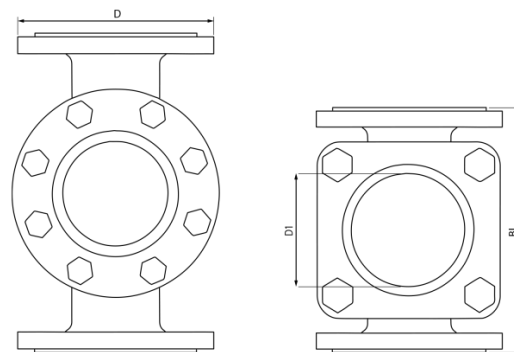

## EXECUTION

DN 15 – 50 Rectangular flanges  
DN 65 – 200 Round flanges

DN	15	20	25	32	40	50	65	80	100	125 <sup>1</sup>	150 <sup>1</sup>	200 <sup>1</sup>
D (PN10)	95	105	115	140	150	165	185	200	220	250	285	340
D (PN16)	95	105	115	140	150	165	185	200	220	250	285	340
D (PN25)	95	105	115	140	150	165	185	200	235	270	300	-
D (PN40)	95	105	115	140	150	165	185	200	235	270	300	-
BL	130	150	160	180	200	230	290	310	350	400	480	600
D1	32	32	48	48	65	80	80	100	125	150	175	175

1) According to DIN 11869

**PRODUCT CODE**

Example for Explaining the Code Composition

**11 - 550V - 6 - 2 - 3 - 1 - 18 - 0**

GROUP	TYPE	DN	PN	BODY	GLASS	GASKET	VARIANT
11	550V	1) 15	1) 10	3) 1.4408	1) Borosilicate glass DIN 7080	18) novaflon® 500	0) Standard variant
		2) 20	2) 16	8) Special	2) Soda-lime glass DIN 8902		
		3) 25	3) 25		4) META® glass		
		4) 32	4) 40		8) Special		
		5) 40					
		6) 50					
		7) 65					
		8) 80					
		9) 100					
		10) 125					
		11) 150					
		12) 200					

INFO: Unless otherwise specified, the highlighted factory standard will be delivered.



Flow sight glass with flange connections suitable to EN 1092-1

**EXAMPLE**

The product code **11-550V-6-2-3-1-18-0** corresponds to the standard version:

ACI type 550V

Nominal size DN 50

Nominal pressure PN 16 (-0.998 to 16 barg)

Body & cover flanges made of 1.4408

Borosilicate glass DIN 7080

Gaskets:

On the media side novaflon® 500

On the atmosphere side novaflon® 500

Screws: A4-70

**QUICK OVERVIEW**



-0.998 to 40 barg



-60°C to 200°C



for liquid media



for gaseous media



Nominal diameters  
DN 15 - 200



Accessories available



TÜV pre-tested

**OPERATING CONDITIONS**

		SIGHT GLASS		GASKETS
		Soda-lime glass DIN 8902	Borosilicate glass DIN 7080	novafion® 500 max. 200 °C
TEMPERATURE	up to 80 °C	✔	✔	✔
	up to 130 °C	✔	✔	✔
	up to 150 °C	✔	✔	✔
	up to 175 °C	✘	✔	✔
	up to 200 °C	✘	✔	✔
PRESSURE	up to 16 barg	✔	✔	✔
	up to 25 barg	✔	✔	✔
	up to 40 barg	✔	✔	✔

✔ suitable    ✘ unsuitable

OPTIONAL ACCESSORIES

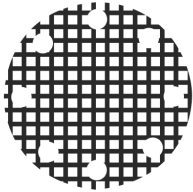

Grid impact protection window

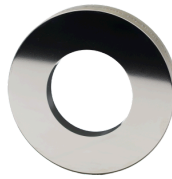

Metal fused safety sight glass

> for safety applications



LED lights

> for Ex and non-Ex areas

NOTE !



The pressure-temperature limits apply according to DIN EN 1092-1!

Our tool with the same name is available on our website.  
([www.aci24.com](http://www.aci24.com), under Service, sub-item Tools)

